



7032 Alondra Boulevard • Paramount, California 90723
P.O. Box 739 • (310) 633-0605

ROOF RACK INSTRUCTION SHEET

1. Remove backing from pressure sensitive adhesive on neoprene gasket and press onto bracket.
2. Assemble rack on the ground and partially tighten set screws in brackets. Brackets should straddle tubing joints, as shown in Figure 2.
3. Place rack on van and square it up.
4. Insert plastic bushings in each screw hole, and attach rack to roof with slotted Hex Head Self-Tapping Screws supplied with rack. (See Figure 1) If Hex Head Driver is not available, mark and pre-drill roof with 1/8" diameter holes and assemble screws with screw driver.
5. Tighten all screws in brackets.

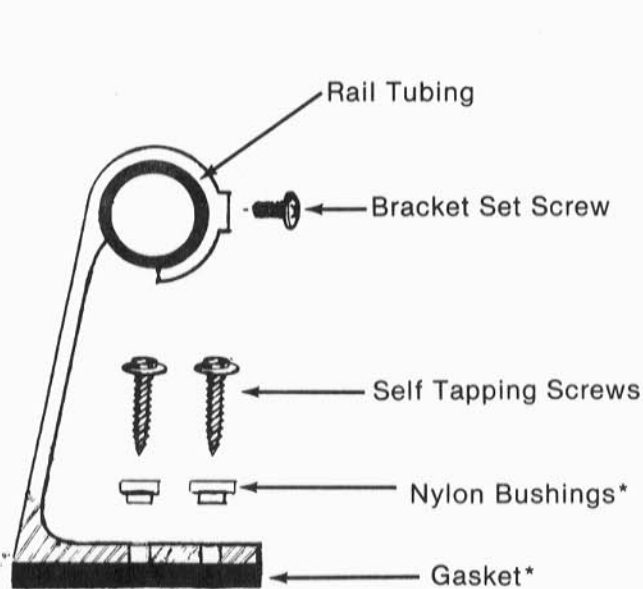

Figure 1 — Bracket Mounting Detail

*These parts are necessary for a secure installation and to insulate rack from roof. Rack can be used as a TV and FM Antenna by using the TV1000 or TV2000 Antenna Kit.

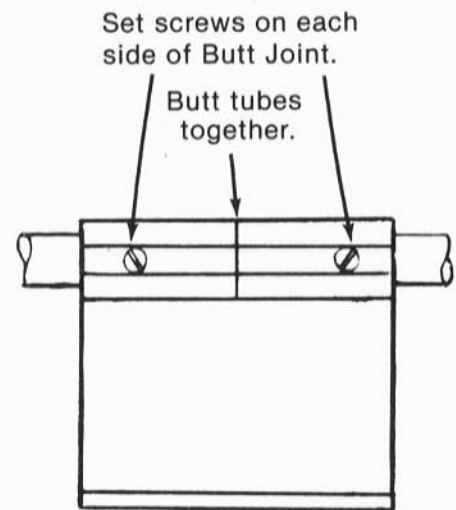

Figure 2 — Inside View of Brackets

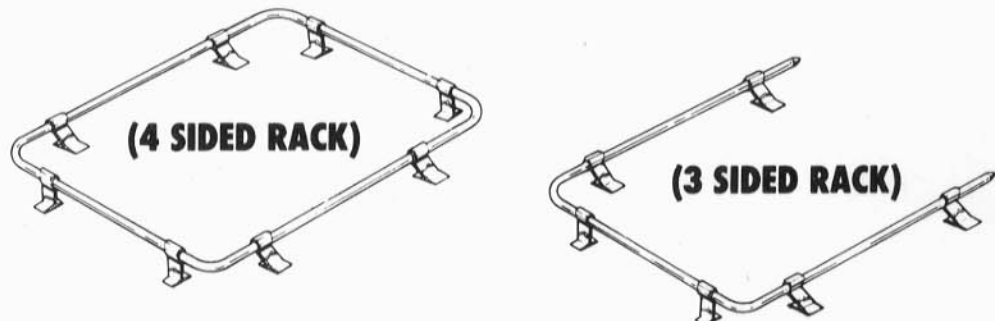

Figure 3 — Assembled Racks

Depending on the rack model, there are either 2 or 3 side brackets per side.



R510 VAN RACK INSTRUCTIONS

1. Remove backing from pressure sensitive adhesive on EPDM gaskets, and press gaskets onto mounting tabs.
2. Place rack on van and square it up.
3. Mark mounting hole locations and pre-drill roof with 1/8" diameter holes.
4. Mount rack to roof, using stainless steel screws provided.

L500 VAN LADDER INSTRUCTIONS

1. Remove backing from pressure sensitive adhesive on EPDM gaskets, and press onto door hangers and mounting tabs.
2. Hook ladder over door and line up so that straight. Pre-drill door with 1/8" diameter holes, in center of mounting tabs.
3. Mount ladder to door, using stainless steel screw provided.

NOTE: Do not obstruct view of license plate. Space has been provided in ladder design for maximum visibility.