

## Installation Instructions

### Checklist:

- Read the Installation Instructions thoroughly prior to installation or use of the MELROSE RACK. The user must pay attention to the company's cautions.
- The Installation Instructions are provided for the user's safety and protection. Top Line Manufacturing is not responsible for the attachment of the MELROSE RACK to the user's vehicle. Installation is beyond the manufacturer's control.

- Although the MELROSE RACK is simple and efficient in its design, it remains the responsibility of the user to exercise good judgment regarding their own personal safety and the safety of those around them at all times.

### Contents in Carton:

	QTY
A - TOWERS:	4
B - MOUNTING PADS:	4
C - PAD GASKETS:	4
D - KEYS:	2

### Hardware Pack for sheet metal:

E - PAD BOLTS (1/4"-20 x 3/4")	8
F - THREADED INSERTS	8

### Hardware Pack for fiberglass metal:

G - PAD BOLTS (1/4"-20 x 1")	8
H - PROPELL NUTS (1/4"-20)	8
I - NUT COVER WASHER	8
J- PLASTIC BOLT COVERS	8

### Supplied Tools and sealants:

K- T-HANDLE ALLEN WRENCH	1
L- THREADED INSERT EXPANDER TOOL	1
M- LOCTITE®	1
N- SILICONE SEALANT	1

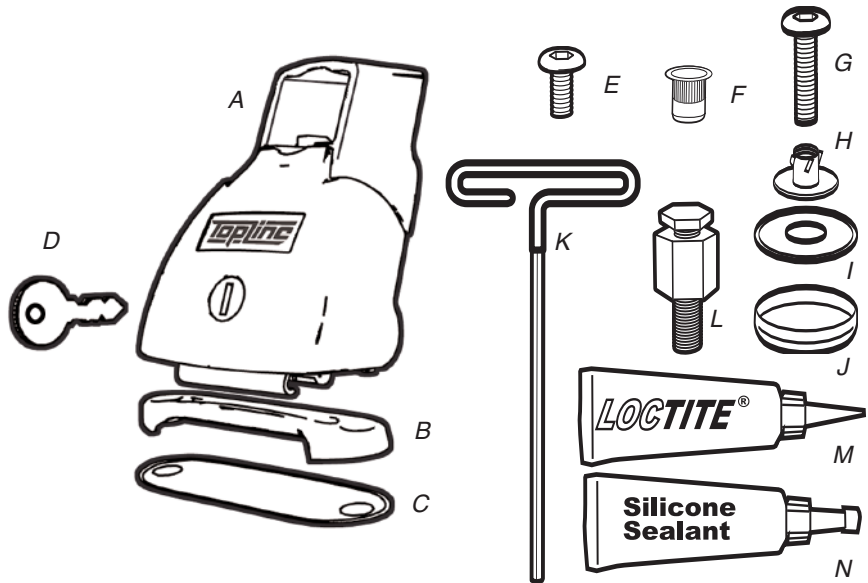

### Contents you will need to purchase:

	QTY
O - RAILS (Round or Rectangular)	2

Length will be based on the vehicles size.

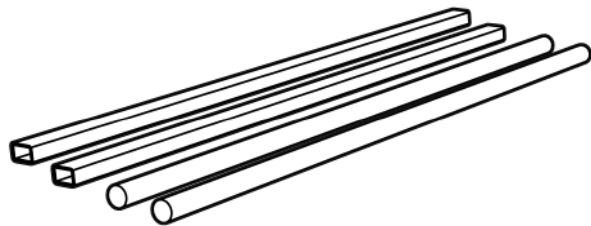

### Tools Required:

- P- ELECTRIC DRILL
- Q- SAFETY GLASSES
- R1- DRILL BIT 1/8"
- R2- DRILL BIT 5/16" (FIBERGLASS ONLY)
- R3- DRILL BIT 25/64"
- S- TAPE MEASURE
- T- PAINTERS TAPE
- U- WRENCH 9/16"
- V- WRENCH 7/16"
- W- HAMMER
- X- CENTER PUNCH
- Y- CHINA MARKER
- Z- SHARPIE MARKER

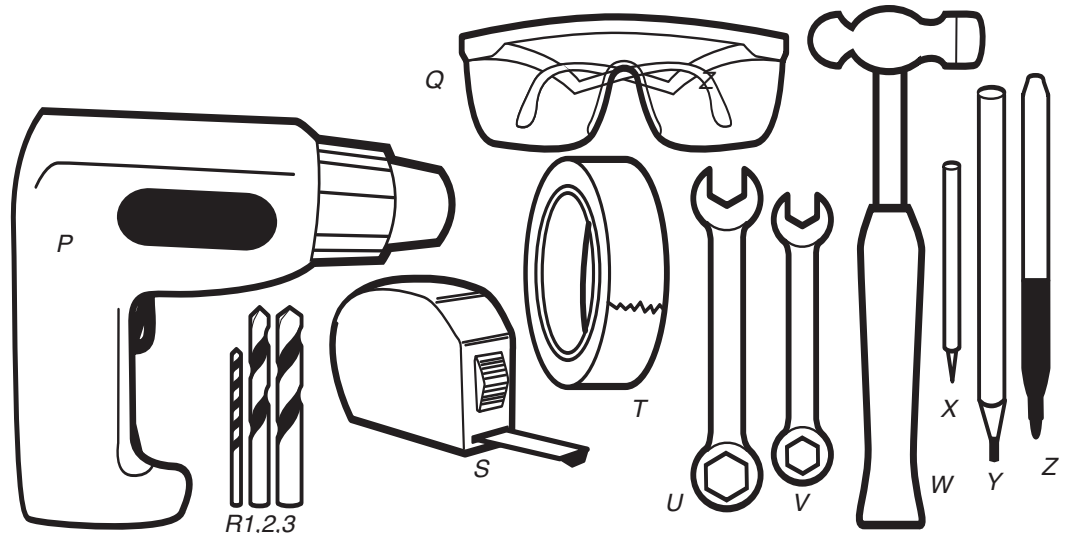

# Choose what type of **INSTALLATION** you need

***Cars, Wagons, Vans and SUVs go to Section A***

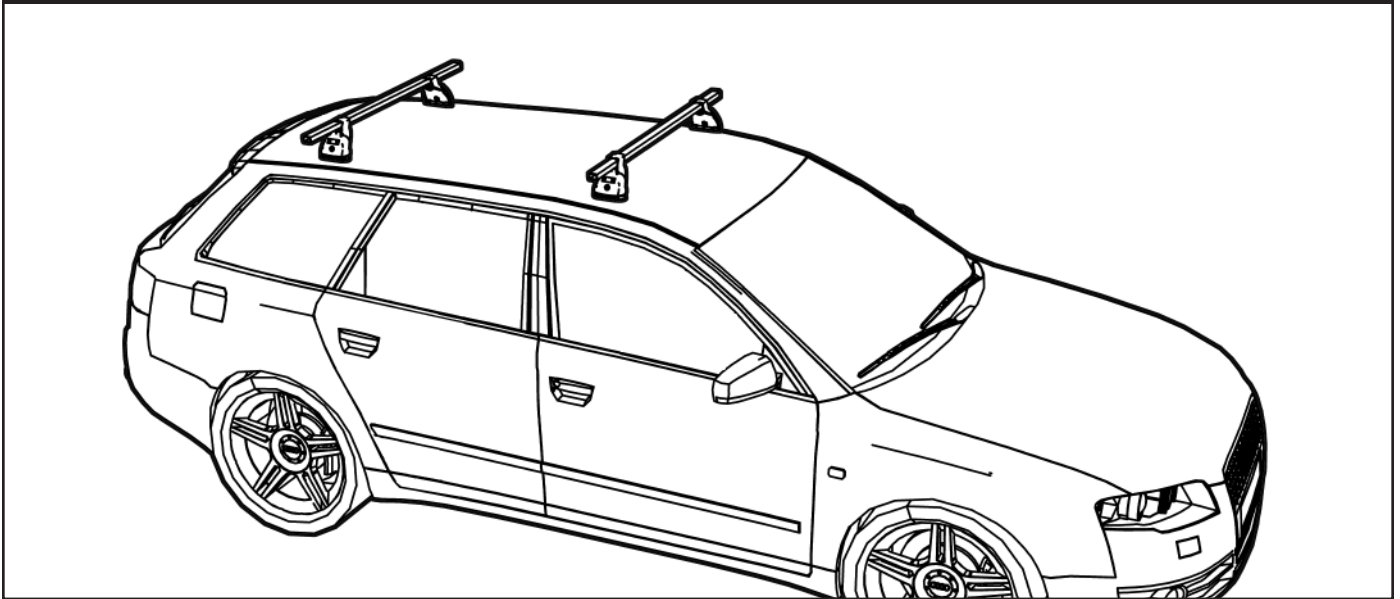

***Fiberglass camper shells and Tonneau Covers go to Section B***

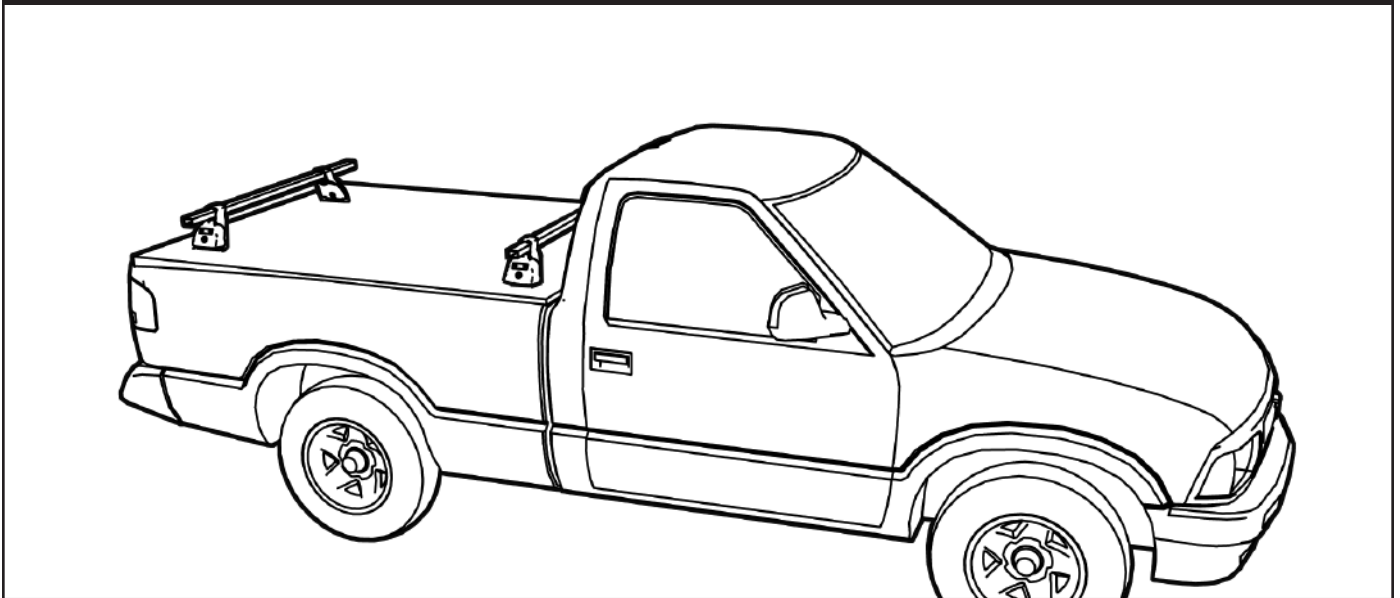

# Section A ( Cars, Wagons, Vans and SUVs )

## READ THE FOLLOWING PRIOR TO INSTALLATION

### Measuring and Placement of Pads

**CAUTION:**

Before you start, check with your DEALER, LOCAL INSTALLER, or VEHICLE MANUFACTURER for placement of cross beams in the roof of your vehicle.

DO NOT MOUNT PAD ASSEMBLIES ON TOP OF CROSS BEAMS.

THIS PRODUCT SHOULD BE INSTALLED BY A PROFESSIONAL INSTALLER.

Call 1-800-653-0605 for more information

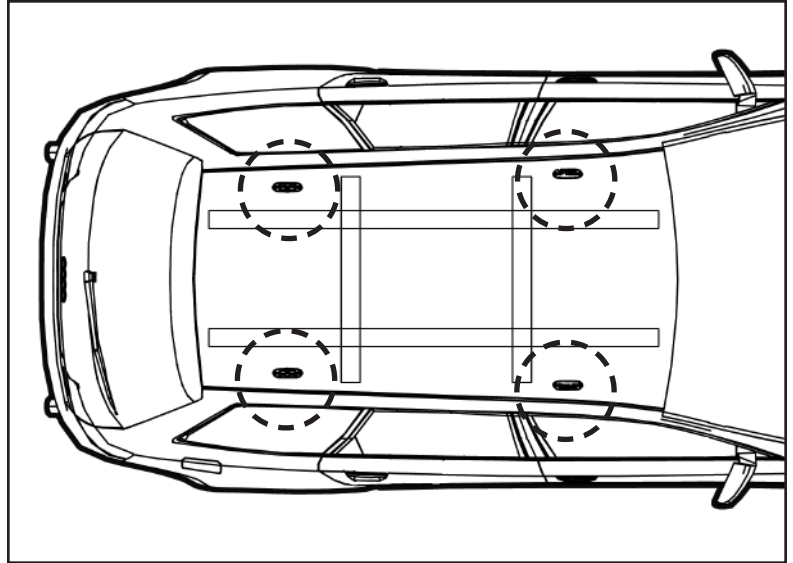

### Step 1

Position Mounting Pad approximately 6-7" from the front and back of roof and 3" side to side. Measure distance between Mounting Pads. Tape roof to mark Mounting Pad locations

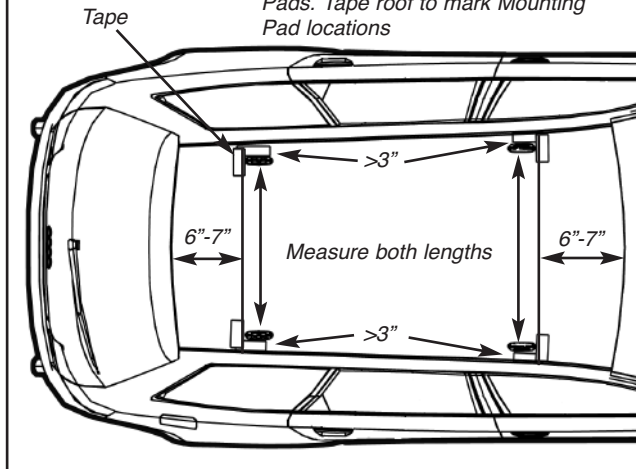

### Step 2

To open Tower pull on both release tabs of Locking Cover. Pull Locking Cover up to open completely

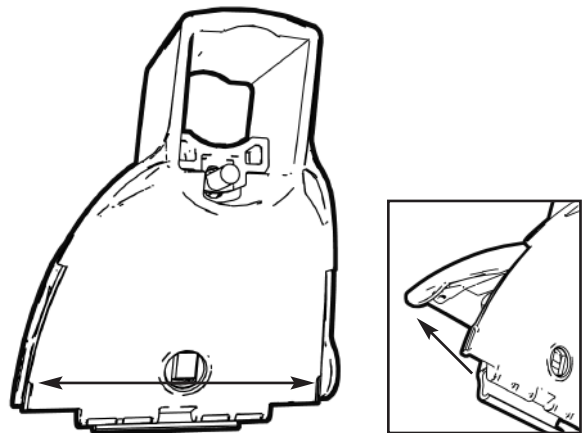

### Step 3

Insert cross bars (round or rectangular) into the top of the tower. If needed loosen Set Screw to ensure bars engage into top of tower.

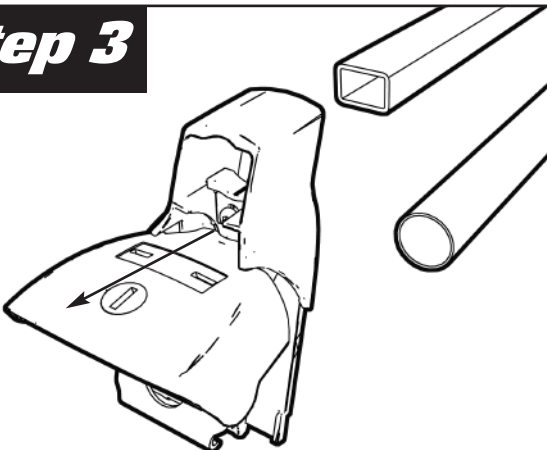

### Step 4

Adjust two Towers with locks facing out on cross bar to match the measurement from the Mounting Pads. Keep the ends of the cross bar equal.

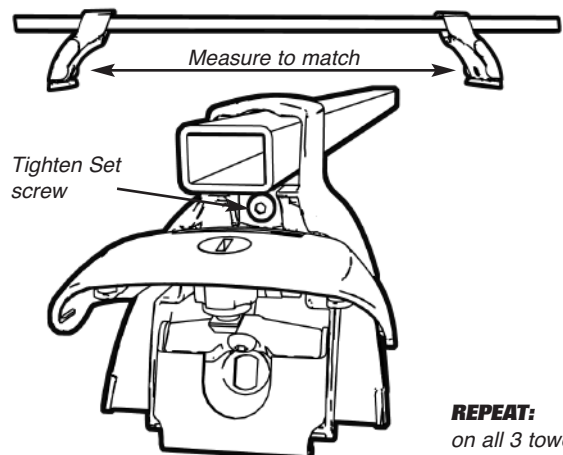

**REPEAT:**  
on all 3 towers

# Section A ( Cars, Wagons, Vans and SUVs )

## Step 5

Place Towers and Cross Bars on roof and align to tape marks. The cross bar should be no closer than 1" to the roof at any point.

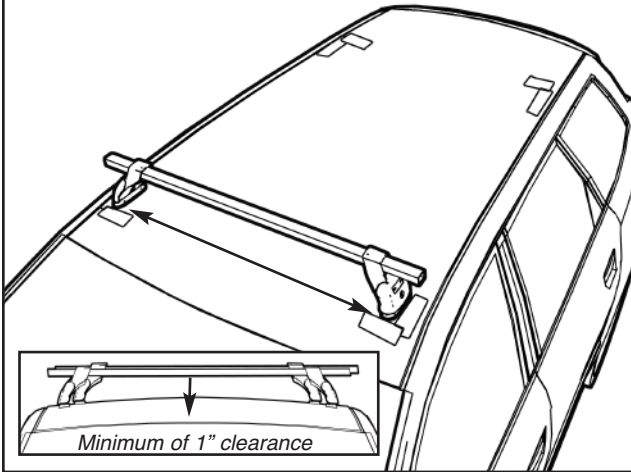

## Step 6

Place the rear Towers and Cross Bar in place and check for 1" clearance.

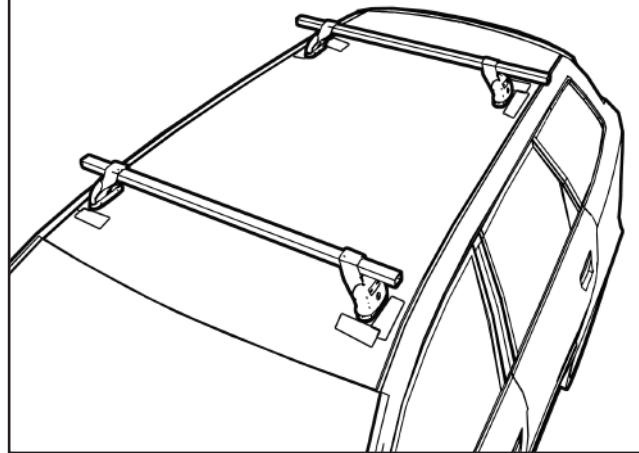

## Step 7

Once the Tower is in the ideal location, remove tape. With the china marker, draw out the footprint location of each Tower.

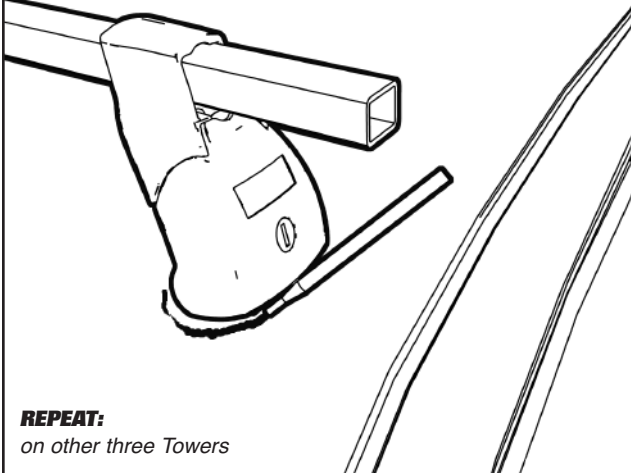

**REPEAT:**  
on other three Towers

## Step 8

Place Mounting Pad and Rubber Pad Gasket in the marked area. Make sure Mounting Pad opening edge is facing out to the doors.

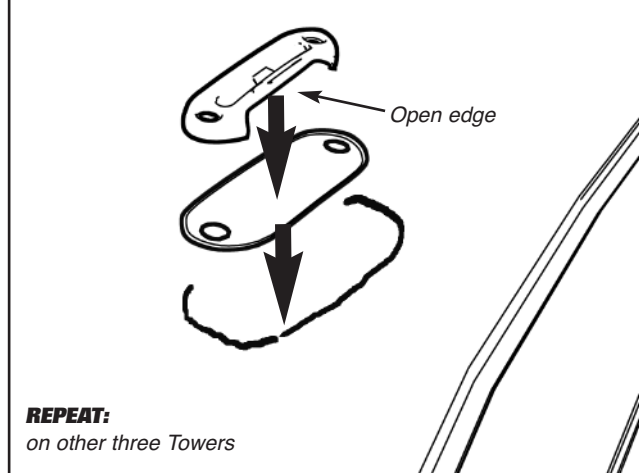

**REPEAT:**  
on other three Towers

## Step 9

Mark the holes on each Pad and Gasket onto the roof.

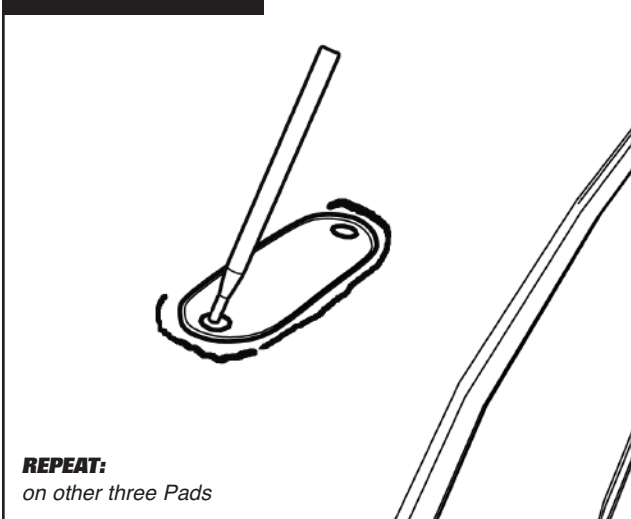

**REPEAT:**  
on other three Pads

## Step 10

Punch both holes.



Wear safety Goggles!

**REPEAT:**  
on other three Pads

# Section A ( Cars, Wagons, Vans and SUVs )

## Step 11

Clean off china marker.

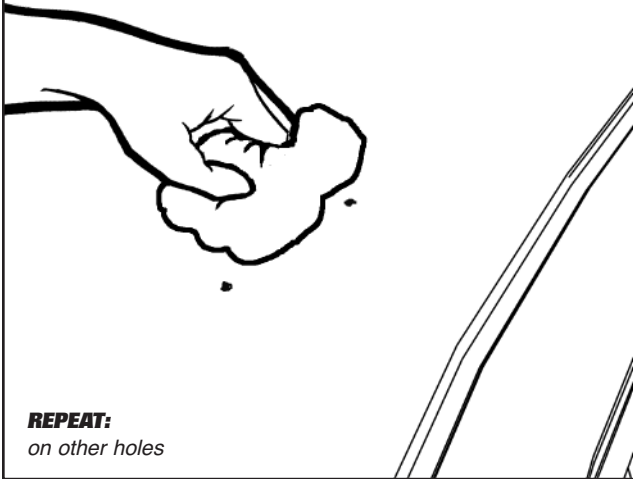

## Step 12

DO NOT DRILL DEEPER THAN 1/4". Use a stop to prevent drilling through vehicle's interior liner. If you do not have a stop, use tape and mark bit 1/4" from tip of both drill bits.

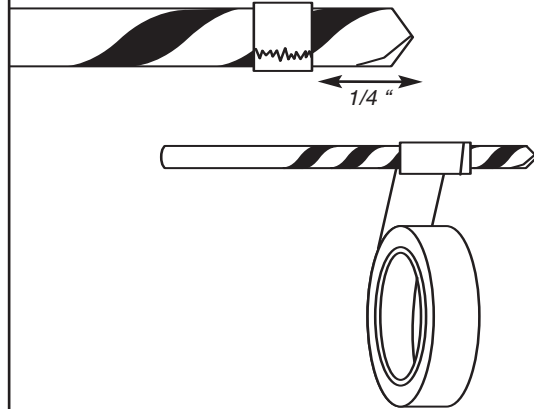

## Step 13

Drill 1/8" pilot hole where you center punched in Step 13

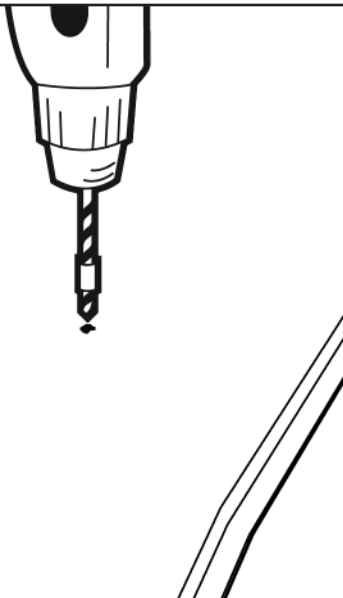

## Step 14

Drill 25/64" hole where you drilled pilot holes in Step 13

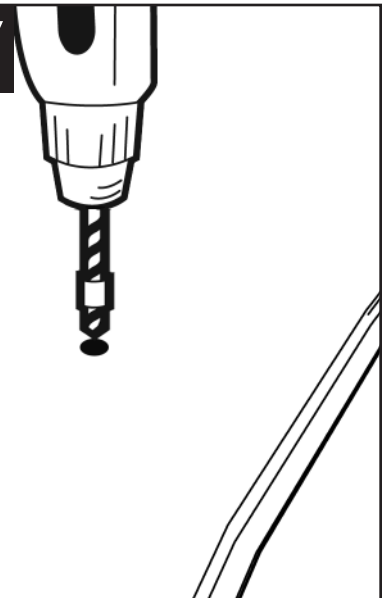

## Step 15

Attach **THREADED INSERT** to **THREADED INSERT EXPANDER TOOL**

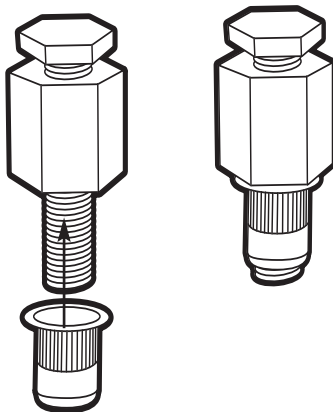

## Step 16

Insert into holes drilled in Step 14.

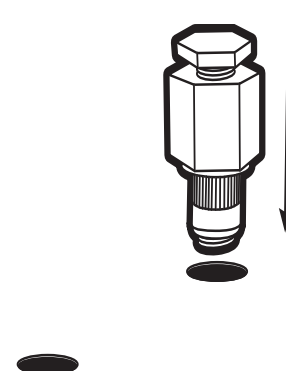

## Section A ( Cars, Wagons, Vans and SUVs )

### Step 17

Tighten top nut on tool using a 7/16" wrench and a 9/16" wrench to hold base. Turn clockwise until tight.

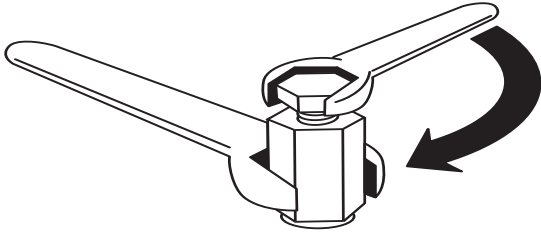

### Step 18

Loosen top nut on tool until it is free of THREADED INSERT. Complete steps 18 thru 21 for other holes.

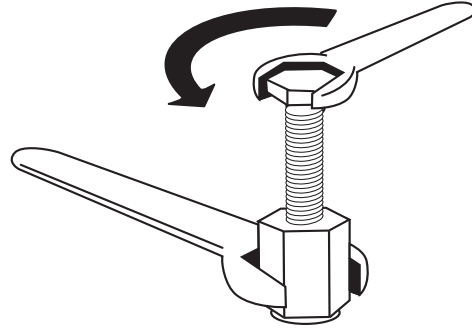

### Step 19

Fill each hole with SILICONE SEALANT.



**REPEAT:**  
on all holes.

### Step 20

Place Mounting Pad and Pad Gasket over holes.

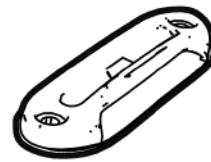

### Step 21

Insert 1/4" - 20 X 3/4" Screw and tighten with supplied T-Handle Allen Wrench.

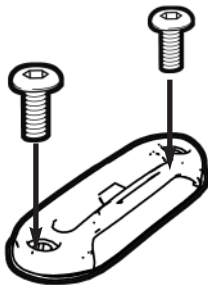

**REPEAT:**  
on other front side

### Step 22

Place Towers and Cross Bar onto Mounting Pads

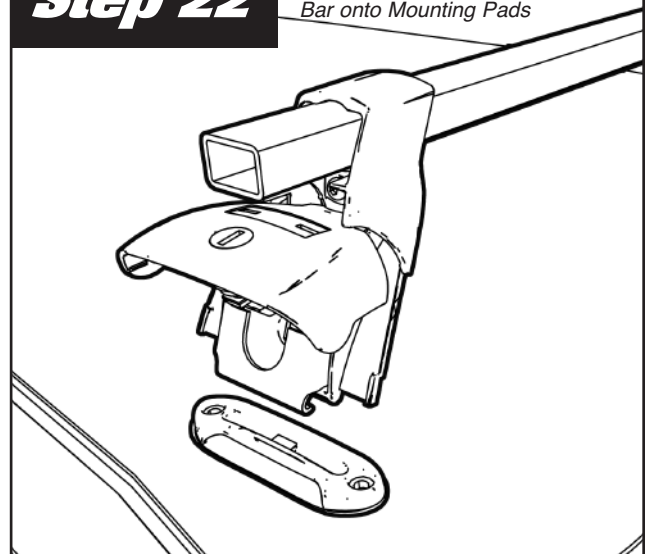

## Section A ( Cars, Wagons, Vans and SUVs )

### Step 23

Push down Grip Clamp Assembly so it's resting on the inside of the Lock Cover. This will give you access to the Set Screw on the Grip Clamp Bracket

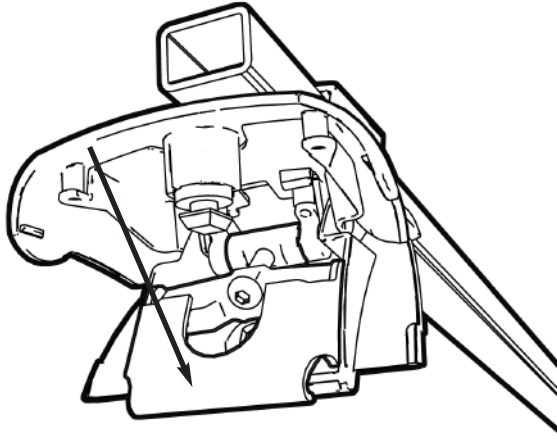

### Step 24

Adjusting the screw on the Grip Clamp Bracket allows for the Tower to get the perfect grip on the mounting pad on any roof line. It may take a few times to get the Grip Clamp Bracket adjusted to a tight fit with no play.

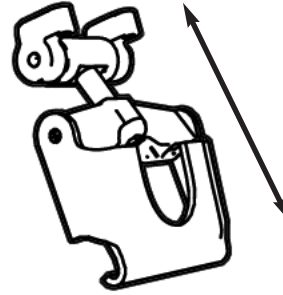

**REPEAT:**  
on all towers

### Step 25

With the allen wrench adjust the Set Screw on Grip Clamp Bracket.

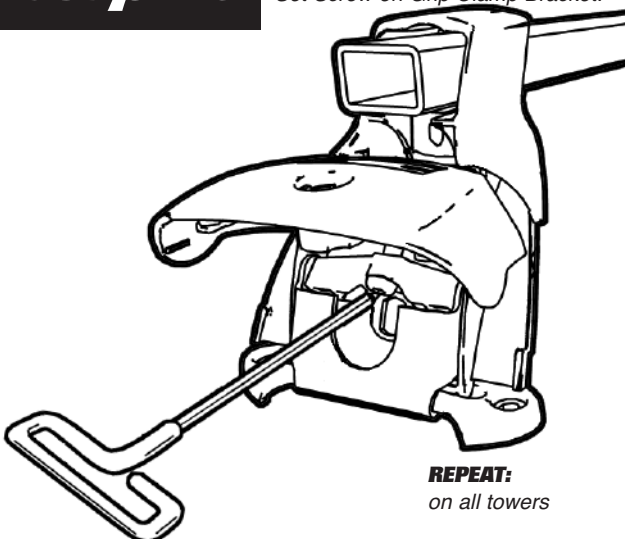

**REPEAT:**  
on all towers

**Proceed to section C**

# Section B ( Truck Camper Shells and Tonneau Covers )

## READ THE FOLLOWING PRIOR TO INSTALLATION

### Measuring and Placement of Pads

**CAUTION:**

Before you start, check with your DEALER, LOCAL INSTALLER, SHELL OR TONNEAU MANUFACTURER for placement of cross beams in the roof of your vehicle.

DO NOT MOUNT PAD ASSEMBLIES ON TOP OF CROSS BEAMS OR GUSSETS.

THIS PRODUCT SHOULD BE INSTALLED BY A PROFESSIONAL INSTALLER.

Call 1-800-653-0605 for more information

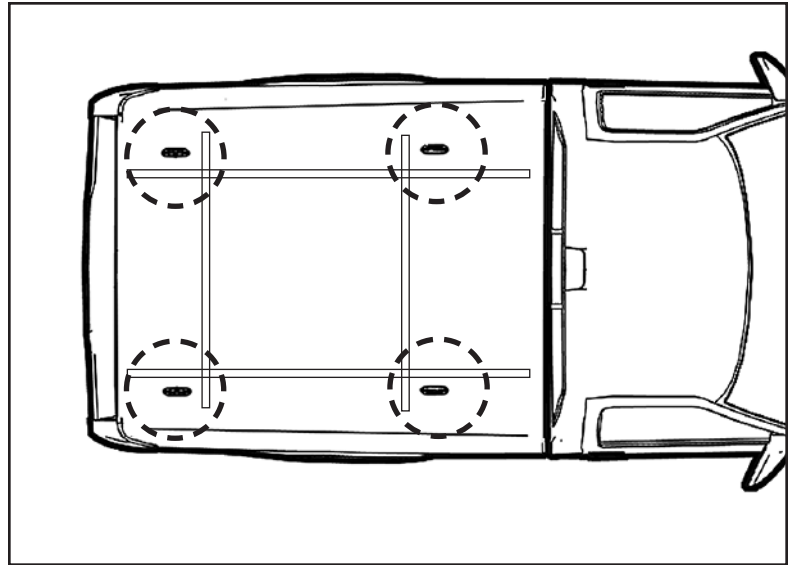

### Step 1

Position Mounting Pad approximately 12"-18" from the cab and 6"-7" from the tailgate and 3" side to side. Measure distance between Mounting Pads. Tape top to mark Mounting Pad locations.

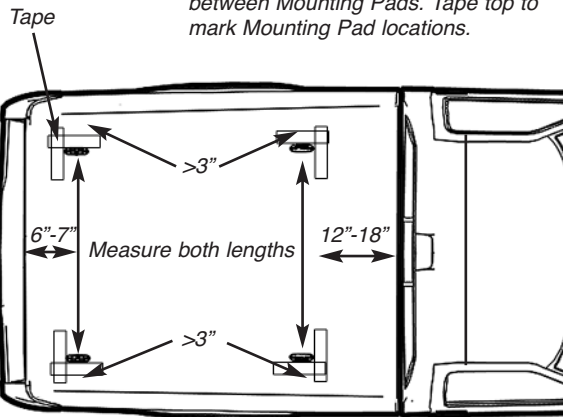

### Step 2

To open Tower pull on both release tabs of Locking Cover. Pull Locking Cover up to open completely.

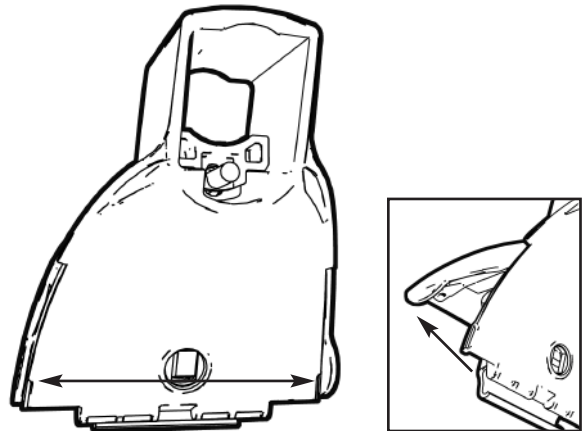

### Step 3

Insert cross bars (round or rectangular) into the top of the tower.

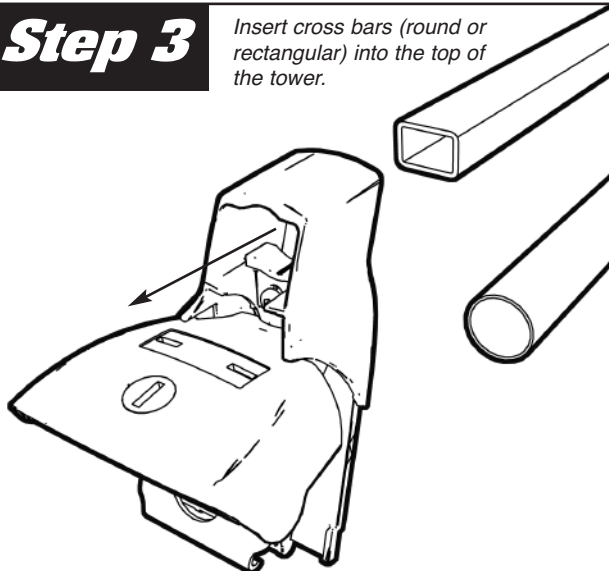

### Step 4

Adjust two Towers with locks facing out on cross bar to match the measurement from the Mounting Pads. Keep the ends of the cross bar equal.

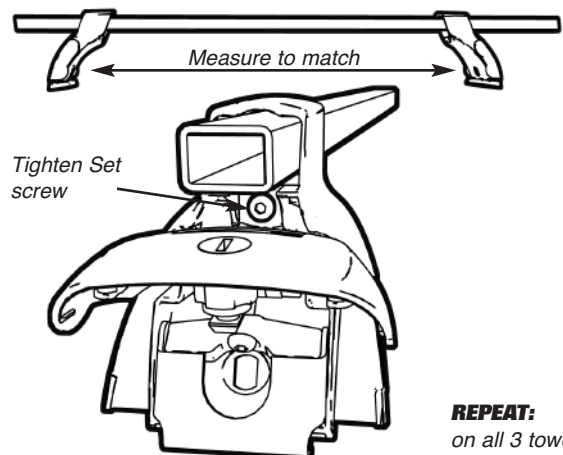

**REPEAT:**  
on all 3 towers



## Section B ( Truck Camper Shells and Tonneau Covers )

### Step 5

Place Towers and Cross Bars on camper or tonneau and align to tape marks.

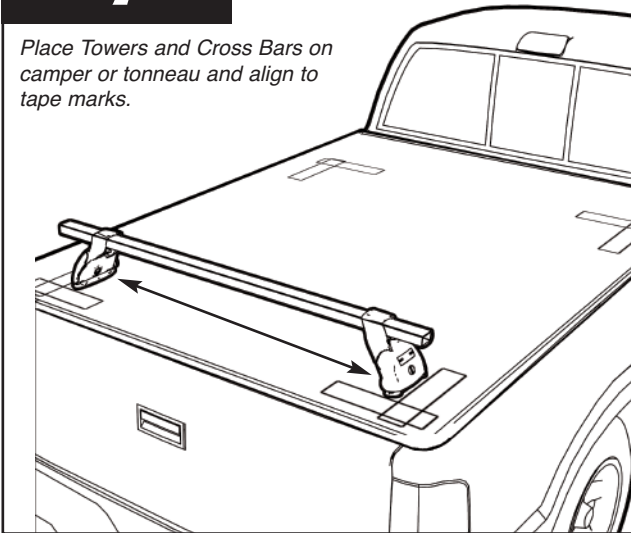

### Step 6

Place the rear Towers and Cross Bar in place and check for alignment.

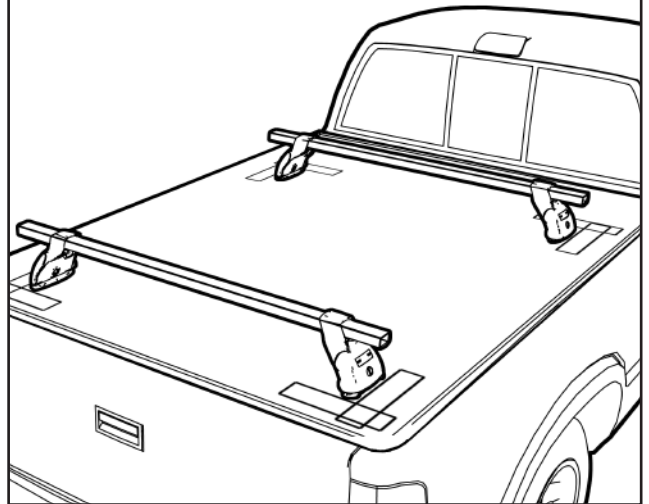

### Step 7

Once the Tower is in the ideal location, remove tape. With the china marker, draw out the footprint location of each Tower.

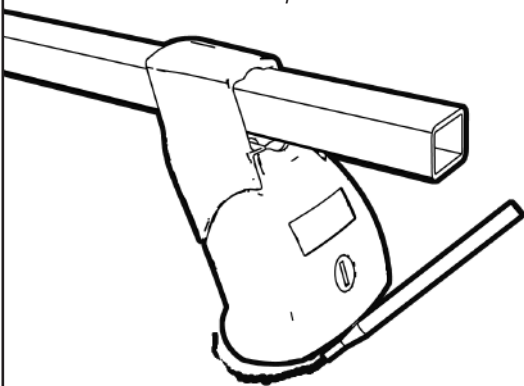

**REPEAT:**  
on other three Towers

### Step 8

Place Mounting Pad and Rubber Pad Gasket in the marked area. Make sure Mounting Pad opening edge is facing out to the doors.

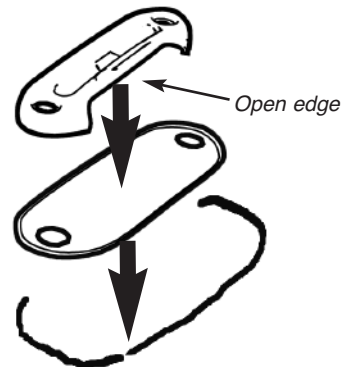

**REPEAT:**  
on other three Towers

### Step 9

Mark the holes on each Pad and Gasket onto the roof.

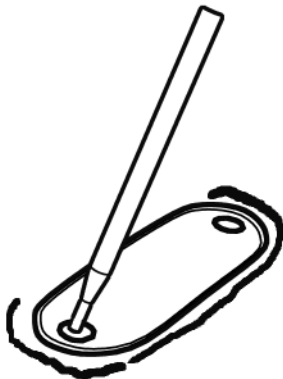

**REPEAT:**  
on other three Pads

### Step 10

Lightly punch both holes, being careful of the fiberglass finish.

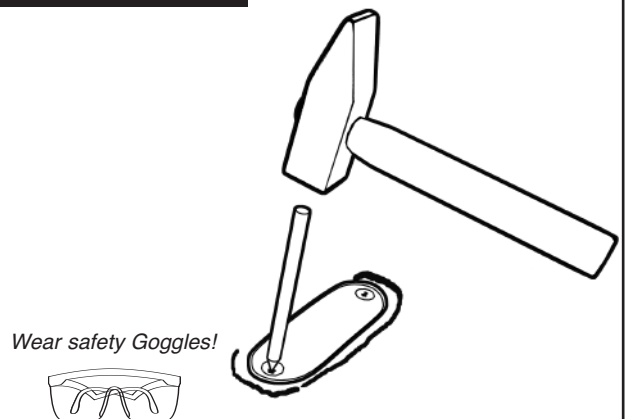

Wear safety Goggles!

**REPEAT:**  
on other three Pads

## Section B ( Truck Camper Shells and Tonneau Covers )

### Step 11

Clean off china marker



**REPEAT:**  
on other holes

### Step 12

Drill 5/16" hole where  
you center punched in  
Step 10.

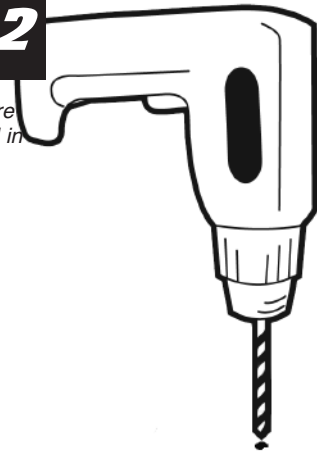

**REPEAT:**  
on other holes

### Step 13

Press Propell Nut and Nut  
Cover Washer into the hole  
from the underside of the  
Tonneau/Shell.

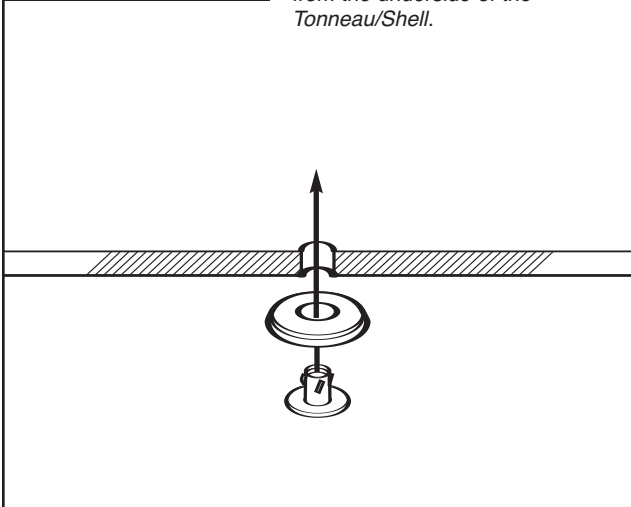

### Step 14

Place Mounting Pad and Pad  
Gasket over holes.

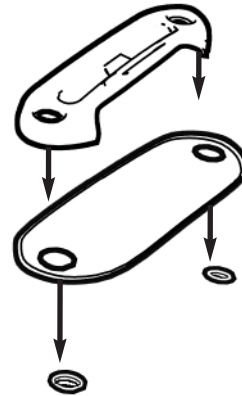

### Step 15

Insert 1/4" - 20 X 1" Screw and  
tighten with supplied T- Handle  
Allen Wrench.

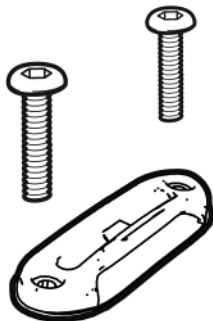

**REPEAT:**  
on other front side

### Step 16

Place Towers and Cross  
Bar onto Mounting Pads

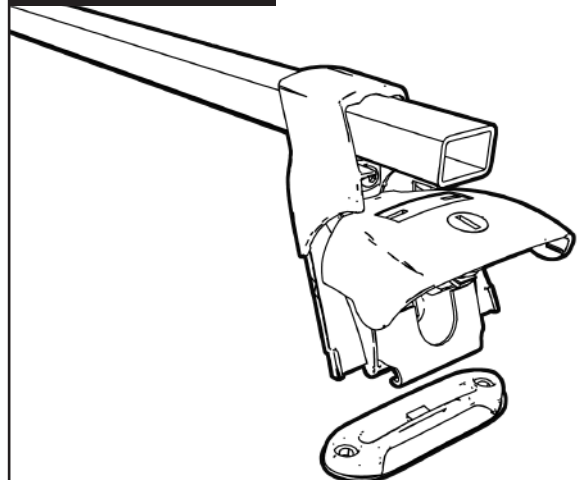

## Section B ( Truck Camper Shells and Tonneau Covers )

**Step 17** Push down Grip Clamp Assembly so it's resting on the inside of the Lock Cover. This will give you access to the Set Screw on the Grip Clamp Bracket

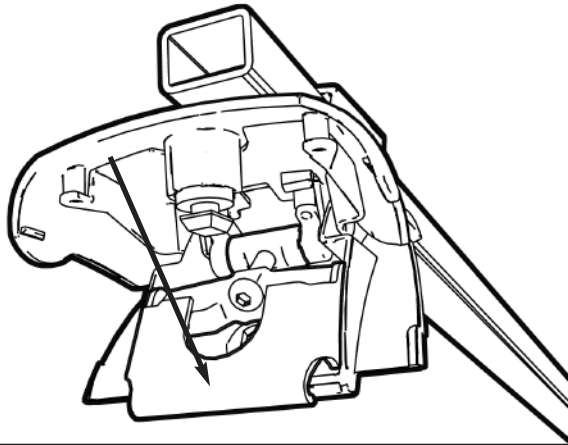

**Step 18** Adjusting the screw on the Grip Clamp Bracket allows for the Tower to get the perfect grip on the mounting pad on any roof line. It may take a few times to get the Grip Clamp Bracket adjusted to a tight fit with no play.

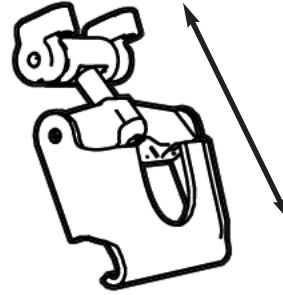

**REPEAT:**  
on all towers

**Step 19** With the allen wrench adjust the Set Screw on Grip Clamp Bracket.

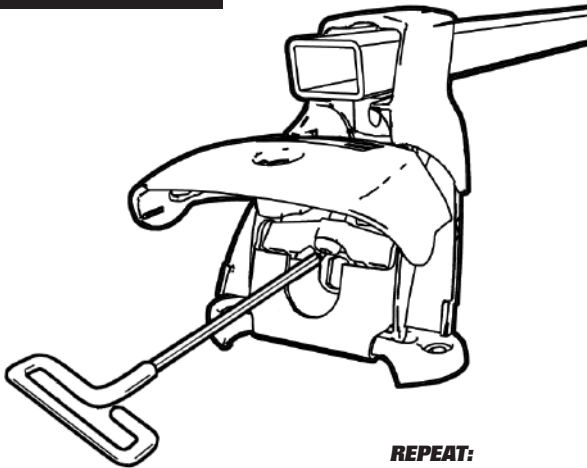

**REPEAT:**  
on all towers

**Step 20** Snap Plastic Bolt Covers on for protection.

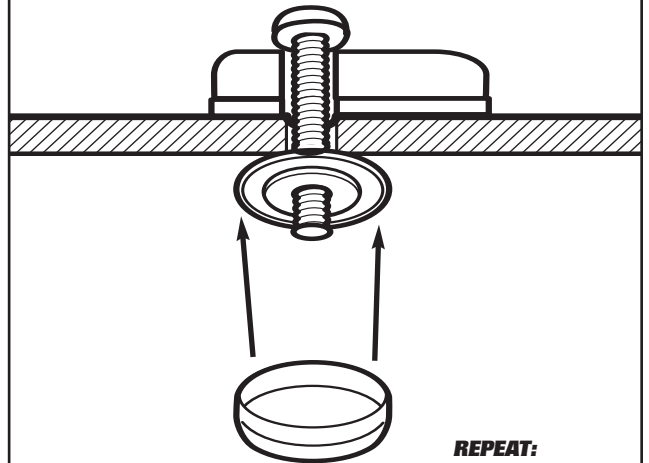

**REPEAT:**  
on all towers

**Proceed to section C**

## Section C ( Attaching Towers )

### Step 1

Test to make sure that all Towers are seated well into the Mounting Pad. Firmly tighten Cross bar Set Screw.

Tighten Set Screw

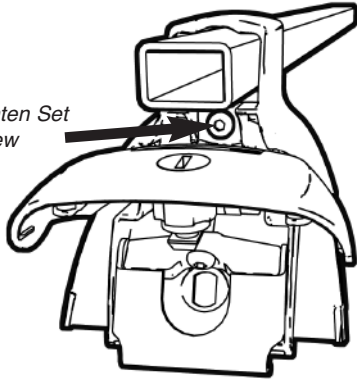

**REPEAT:**  
on all 3 towers

### Step 2

Place Tower into the Mounting Pad groove.

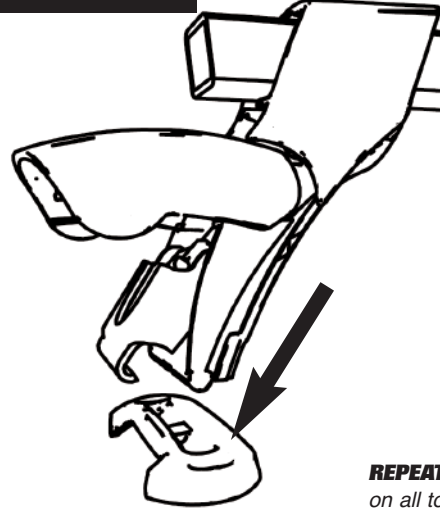

**REPEAT:**  
on all towers

### Step 3

Push the Grip Clamp Bracket lip so that it grabs the lead edge of the mounting pad.

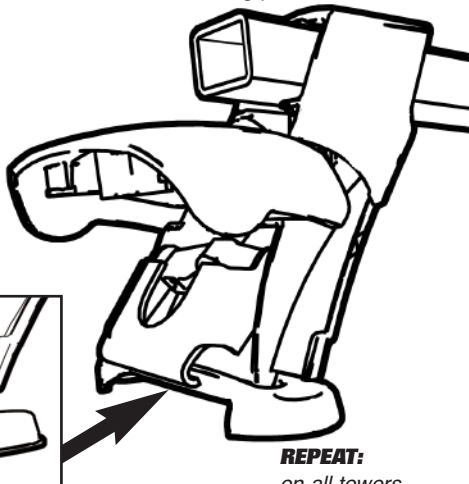

**REPEAT:**  
on all towers

### Step 4

Snap flap closed to engage the Grip Clamp Bracket onto the Mounting Pad

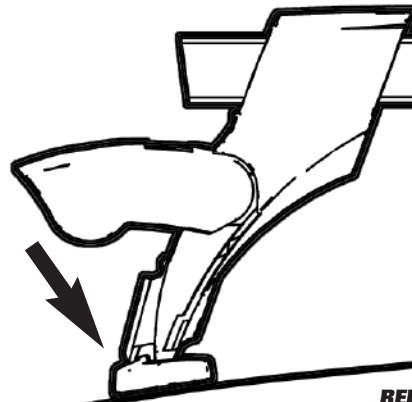

**REPEAT:**  
on all towers

### Step 5

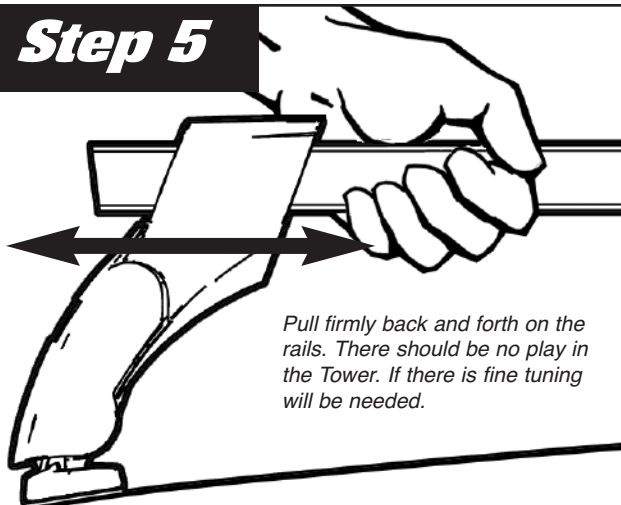

Pull firmly back and forth on the rails. There should be no play in the Tower. If there is fine tuning will be needed.

**REPEAT:**  
on all towers

### Step 6

Snap flap open. To make final adjustments if needed.

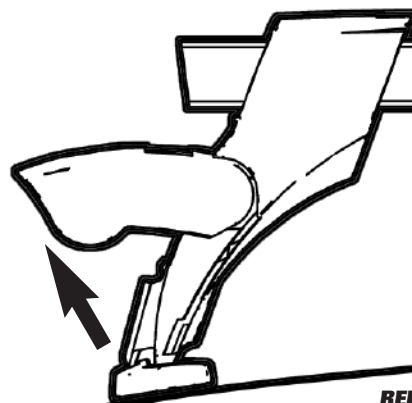

**REPEAT:**  
on all towers

## Section C ( Attaching Towers )

### Step 7

Snap the flap closed and lock after there is no play in all four Towers

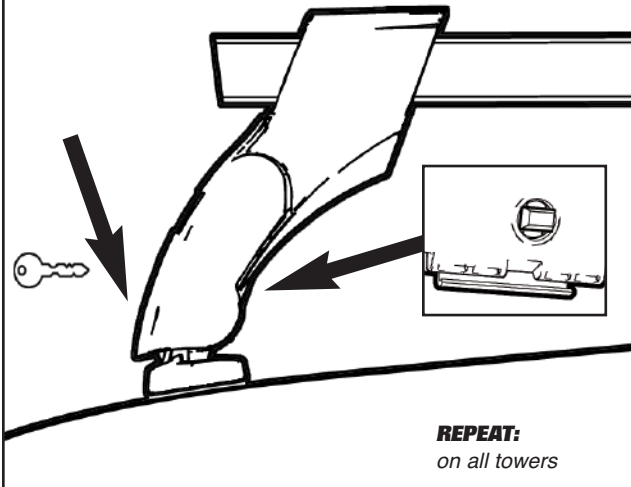

### Step 8

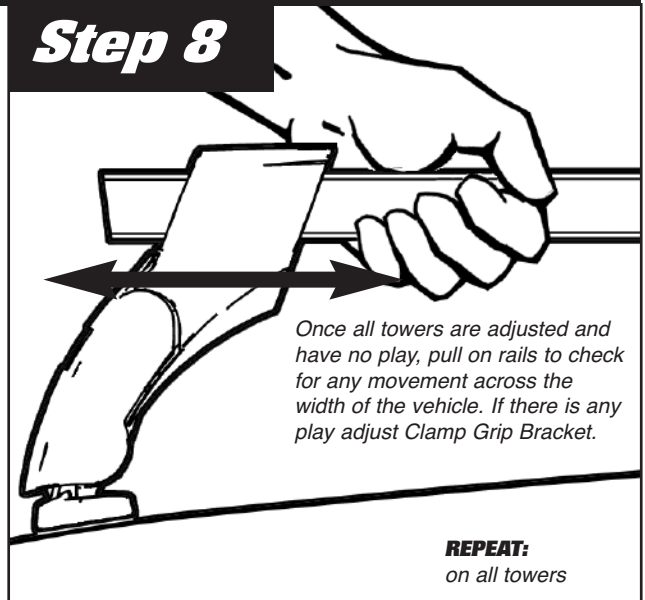

### Step 9

Now pull on rails to check for any movement across the length of the vehicle. If there is any play adjust Clamp Grip Bracket.

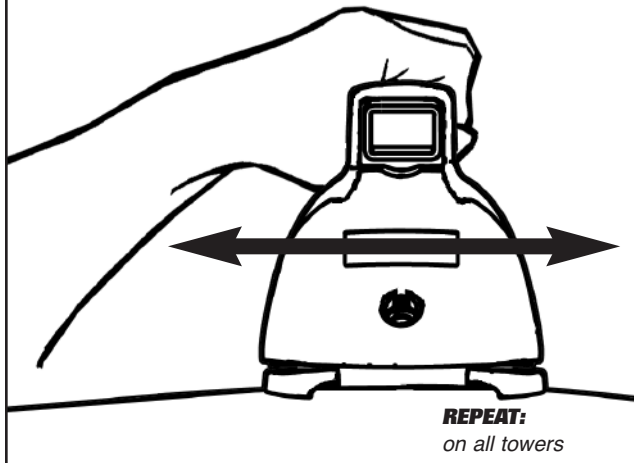

### Step 10

Flip Towers and Cross Bars upside down. Push down Grip Clamp Assembly so it's resting on the inside of the Lock Cover.

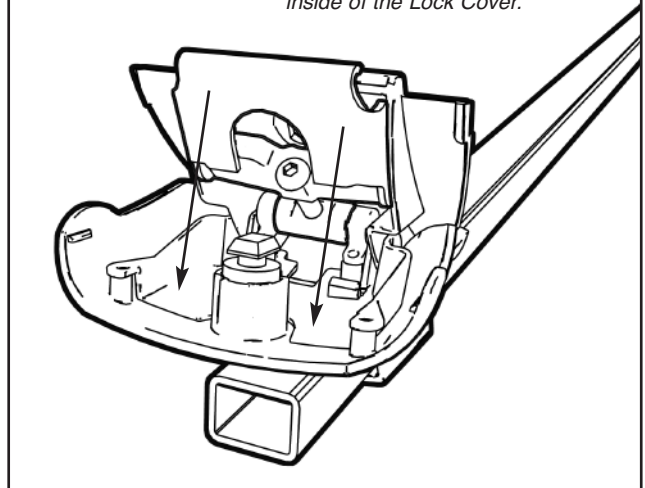

### Step 11

Put Loctite® on the cylinder shaped nut where the Set Screw enters it. The loctite will completely cure within 24 hours.. **Do not put under load for 24 Hours**

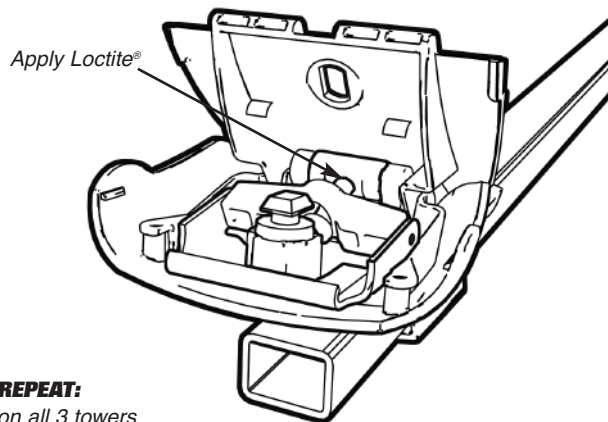

## Congratulations!

You have successfully installed the Melrose RACK SYSTEM. Now you can reattach towers with crossbars and mount your accessories (not included).

# TopLine

FOR MORE INFORMATION PLEASE CONTACT US:  
**TOP LINE MANUFACTURING, INC.**

7032 Alondra Blvd., Paramount, CA 90723

Toll Free: (800) 653-0605

Local: (562) 633-0605

Fax: (562) 633-6550

E-mail- [info@toplinemfg.com](mailto:info@toplinemfg.com)

Web: [www.toplinemfg.com](http://www.toplinemfg.com)